



Chevy/GM 1500, HD 2500, 3500, Tahoe, Yukon, Hummer, Escalade, Lincoln navigator, Excursion late model, H3 Limo

TORSION BAR Install with SAW Keys

**SWAY-A-WAY
9530 COZYCROFT AVE
CHATSWORTH, CA 91311
818.700.9712
WWW.SWAYAWAY.COM**

Thank you for purchasing our product. Sway-A-Way strives to produce the highest quality product in both form and function.

Disclaimer: Sway-A-Away recommends that all of our products be installed by qualified mechanics. We are not responsible for any damage caused by improper installation. Torsion bars are holding a great amount of energy and can cause serious damage to you and your vehicle.

Tools needed

- Jack
- Jack stands
- Sockets
- Wheel clocks
- Torsion bar removal tool (puller)



REFER TO THE IMAGE ON PAGE 3 FOR ALL PARTS MENTIONED

Step 1: Start by placing the vehicle in neutral, place wheel clocks on rear wheels and lift the front of the vehicle. Place jack stands to securely hold the vehicle in its lifted position.

Step 2: Start by measuring and recording how much thread is left on each adjuster bolt; you will use this number in a future step to adjust the new torsion bars to your current ride height.

Step 3: Remove the adjuster bolt completely on one side at a time. Put some WD-40 or other lubricant on the bolt if it is rusty and hard to remove. **Use extreme caution as bar is under great stress.**

Step 4: Once you have removed the bolt, use a torsion bar removal tool to safely get the stock torsion bar adjuster nut off by loading the torsion bar with the puller. Once it is free remove the nut adjuster.

Step 5: Unload the puller and push the torsion bar to the front, when you do this the stock key should be free. After the stock key is free remove the torsion bar by maneuvering out of the control arm and out of the car.

Step 6: Grease both ends of the torsion bar as well as the control arm cavity and the cross member cavity. Install the SAW torsion bars from the rear of the car making sure that you place the left bar on the left side and the right bar on the right side. The hex end should go into the control arm and the splined end will go into your new SAW key. SAW torsion bars have an L or an R stamped in one end of the bar. **Note: if SAW keys do not come in your kit, install stock keys. Also, if installing H3 Limo torsion bars, both sides are a hex and disregard the spline information given above.**

Step 7: Once the bar is in the proper position in the control-arm, slide the new key **(or stock key)** into the cross member cavity and then insert the splined end **(hex if installing H3 limo bars)** of the torsion bar into the key. Using the puller tool, load the key until you can add the stock nut adjusters. Once the stock nut adjuster is placed remove the puller tool and tighten the adjuster bolt according the measurements recorded in step 2.

Step 8: Lower the vehicle back on the ground and drive it around the block to fully settle the suspension.

Step 9: Adjust the ride height to the desired setting.

Step 10: Check and/or adjust the wheel alignment.

Make sure to get your car aligned after the installation by a qualified professional.

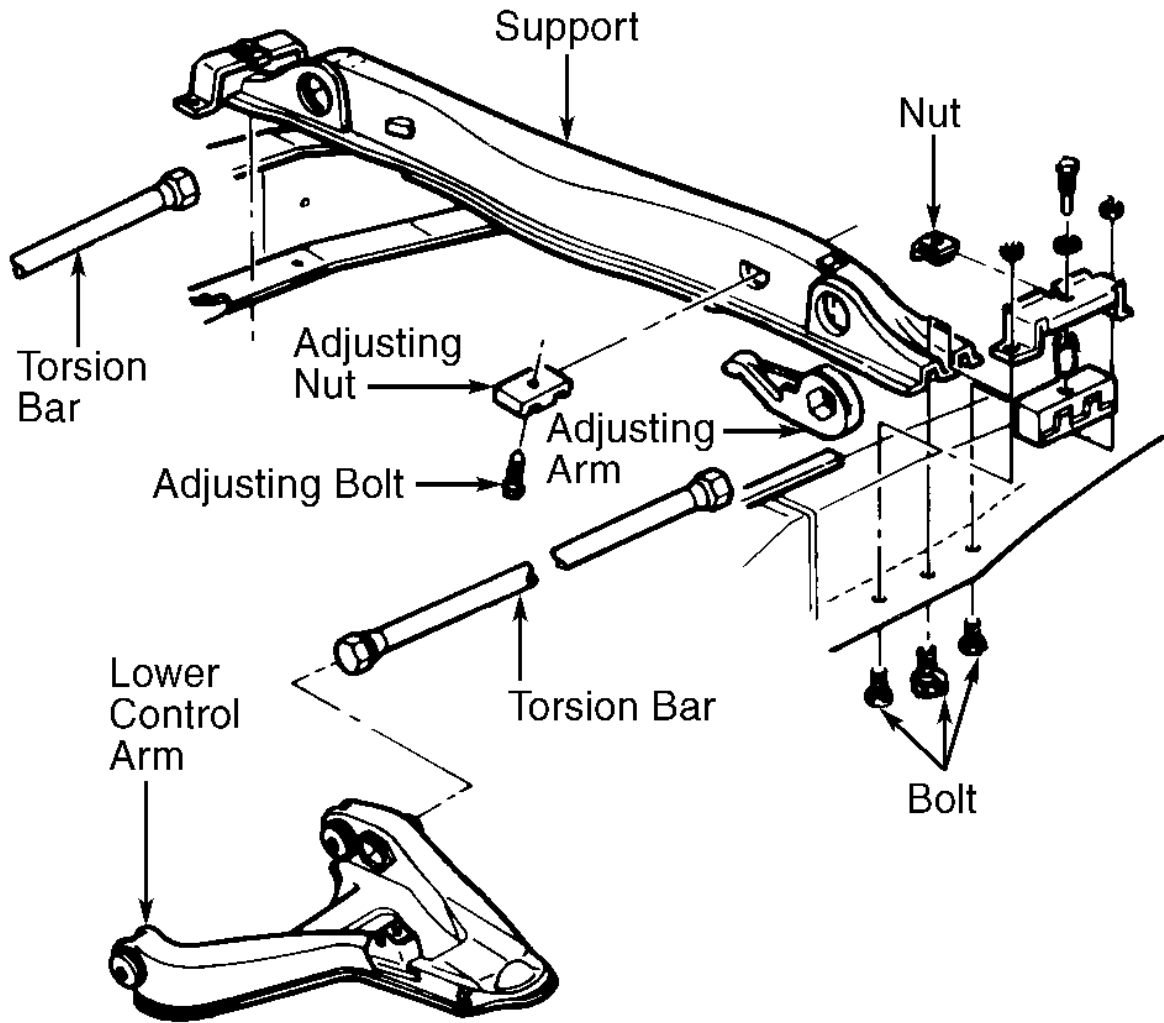

G90E04806